

ref. **53684**

30 TON PRESS

Function

This hydraulic workshop press with 30 tons of pressing force is the ideal aid for works in different fields, such as handicraft, industry, agriculture, gardening and landscaping etc.

Advantages

- ✓ Manual and foot-operated.
- ✓ Adjustable in 10 height levels.
- ✓ With winch to regulate the height of the pressure table.
- ✓ Pressure gauge integrated in the chassis.

Technical specification

| | |
|---------------------|------------------------|
| Capacity | 30T |
| Stroke | 150mm |
| Operating range | 166-1126mm |
| Levels | 10 |
| Working table width | 540mm |
| Lateral stroke | 200mm |
| Dimensions | 750x780x1838 cm |
| Weight | 206kg |



Size

| | |
|---|-------------|
| A | 780 |
| B | 540 |
| C | 1808 |
| D | 1838 |
| E | 750 |
| F | 180 |
| G | 180166-1126 |
| H | 150 |
| M | 200 |

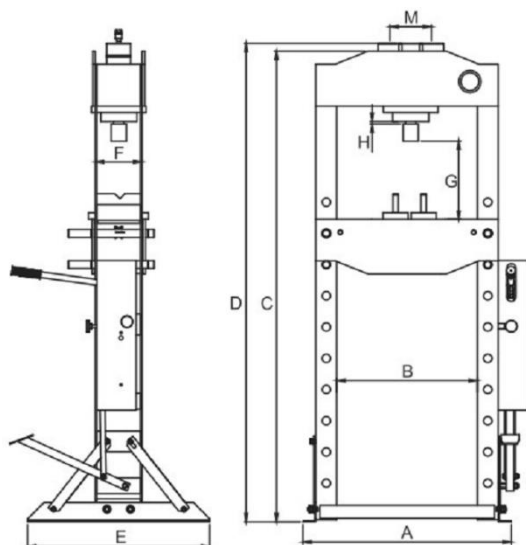

Quality standards

Directive 2006/42/EC
 EN 693:2001+A1:2009,
 EN ISO 12100:2010